

Air Vantage

Key features:

- Fibreglass composite construction
- Visually striking appearance
- Fast transient response
- Standard red, black and white finishes, optional custom colours

Applications:

- High impact nightclubs
- DJ monitoring



The Air Vantage can either be used as a stand-alone mid-top with LF enclosures in a main club system, or be paired with the Sub Vantage for monitoring duties. The same attributes that make it eminently suitable as a DJ monitor, such as true point source transmission and a smooth frequency response, also shine when it comes to filling a dance floor with high SPL and accurate sound.

Particular attention was paid when designing its internal crossover to achieve the best possible phase response, which has allowed for prolonged listening periods at very high SPLs, with minimum fatigue. Venues with low ceilings are also a prime candidate for the mid-top, as its diminutive vertical dimensions and tight pattern control allow for close mounting to a ceiling.

A fully adjustable mounting bracket is available, allowing any desired amount of vertical tilt to be applied. A Neutrik speakON™ NL4s is provided for driver connections.

Specifications

Frequency Response	140 Hz - 20 kHz ± 3 dB
Efficiency ¹	107 dB 1W/1m
Crossover Points	1.6 kHz passive
Nominal Impedance	8 Ω
Power Handling ²	500 W AES
Maximum Output ³	127 dB cont : 133 dB peak
Driver Configuration	1 x 12" - 1 x 1.5" coaxial
Dispersion	70°H x 40°V
Connectors	1 x 4-pole speakON™ NL4
Weight	23.5 kg (51.8 lbs)
Enclosure	Smooth cellulose
Mounting	Tilt adjustable mount (optional)
Colour	Custom colours available upon request

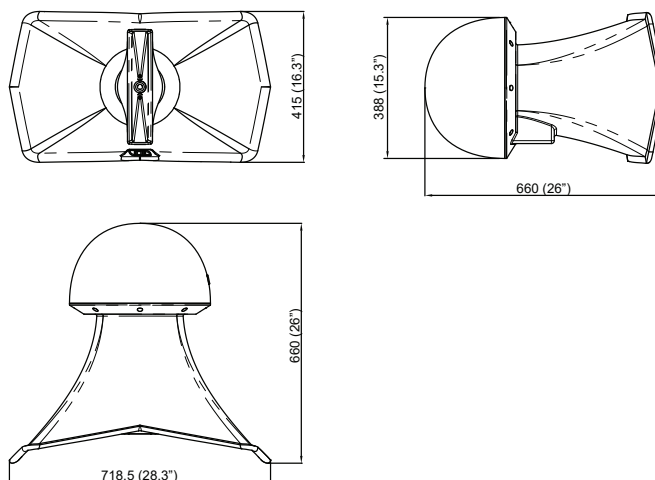

¹ Measured in half space ² AES2 - 1984 compliant ³ Calculated

Air Vantage

Architectural specification

The loudspeaker shall be a passive, two-way system consisting of one high power 12" (304.8 mm) horn loaded low frequency (LF) transducer and 1.5" (25 mm) exit co-axial high frequency (HF) compression driver mounted in a high precision waveguide within an aesthetically designed enclosure.

The co-axial transducer shall be constructed on a cast aluminium frame, with the low frequency transducer consisting of a treated paper cone with its dust cap removed and a 25.4 mm (1") voice coil, wound with copper wire on a high quality voice coil former, with neodymium magnets for high power handling and long-term reliability.

The high frequency transducer, which also uses neodymium magnets, shall be bolted through the rear of the magnet structure belonging to the low frequency transducer to form a co-axial drive unit. The sound will project through a machined waveguide that exits in the centre of the low frequency transducer coupling with its horn by using the 718 mm (28.3") baffle diameter of such horn to achieve greater SPL and pattern control on high frequencies.

Performance specifications for a typical production unit shall be as follows: the usable on-axis bandwidth of 140 Hz to 20 kHz (± 3 dB), with an average 40° directivity pattern in the vertical axis and 70° in the horizontal one (-6 dB down from on-axis level) from 1 kHz to 12 kHz; maximum SPL of 133 dB peak (127 dB continuous) measured at 1 m using IEC268-5 pink noise. Power handling at 500 W AES at a rated impedance of 8 Ω ; crossover point at 1.2 kHz passive. The system shall be powered by its own dedicated power amplification module with DSP management, with the wiring connection via one Neutrik speakON™ NL4 .

The enclosure shall be of a moulded fibreglass composite with a smooth cellulose finish in any RAL colour and an aesthetic design. It shall contain an adjustable tilt mount for rigging and external dimensions of (H) 415 mm x (W) 718.5 mm x (D) 660 mm (16.3" x 28.3" x 26"). Weight shall be 23.5 kg (51.8 lbs).

The loudspeaker shall be the Void Acoustics Air Vantage.

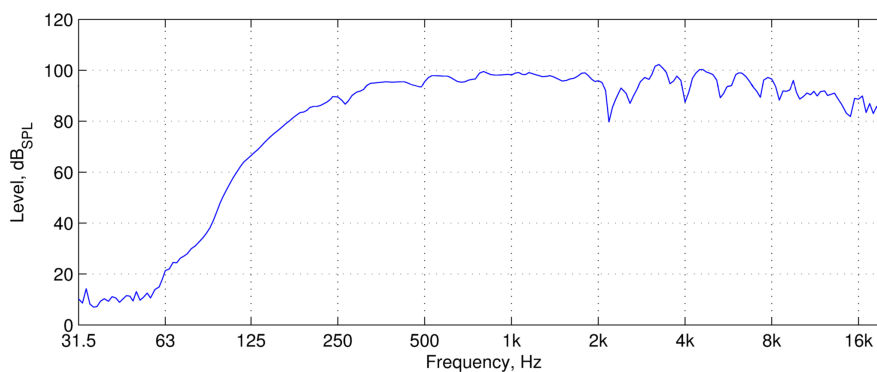

Frequency response (Anechoic measurements)

